

OREGON COAST PHOTOGRAPHERS' ASSOCIATION, INC.

# PROOF SHEET

Volume 27 Edition 3

March 2019

Editor: Carol Todd, [Proofsheet@oregoncoastphotoclub.com](mailto:Proofsheet@oregoncoastphotoclub.com)



1<sup>st</sup> Place Traditional Monochrome EID - Thomas Konomos - Pistol Packing Mama

# Musings from a Muddled Mind

How much do you know about the contortions your camera goes through to achieve that super sharp focus (or maybe not so much) when you finally push the shutter button? You have traveled thousands of miles, found the subject of your dreams, the light is perfect and your composition is museum quality. You should at least expect tack sharpness exactly where you want it.

What happens If you pusha da button and get (horrors) a fuzzy image? WHAT the &^%^^\*&#@# HAPPENED? Well, you could have been the victim of a faulty algorithm or a couple of misplaced ones and zeros. Most digital SLR's and some other cameras use a focusing system called "phase detection". This just means that the camera can detect fuzzy and sharp and which direction it needs to go to get from fuzzy to sharp.



## HOW PHASE DETECTION AUTOFOCUS WORKS

This cross-section of a Nikon D4 shows how the autofocus system works in most DSLRs

### 01 Main mirror

This is semi-silvered so that the image formed by the lens passes mostly up into the pentaprism and the viewfinder, but some passes through on to the sub-mirror behind.

### 02 Sub-mirror

This reflects the image down into the base of the camera where the AF sensor is located. The sub-mirror flattens against the back of the main mirror when it flips up during the exposure.

### 03 Autofocus sensor

Different Nikon D-SLRs use different autofocus sensors – the pro-level D4 uses Nikon's top-of-the-range 51-point Multi-CAM 3500FX sensor.

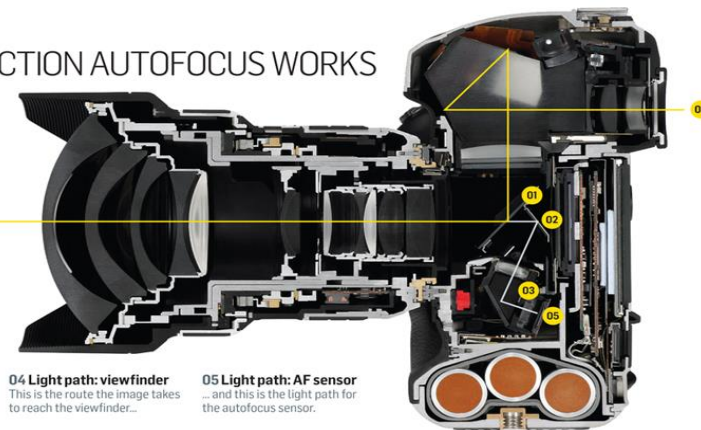

04 Light path: viewfinder  
This is the route the image takes to reach the viewfinder...

05 Light path: AF sensor  
...and this is the light path for the autofocus sensor.

Unlike most other types of digital camera, digital SLRs use separate 'phase-detection' AF sensors

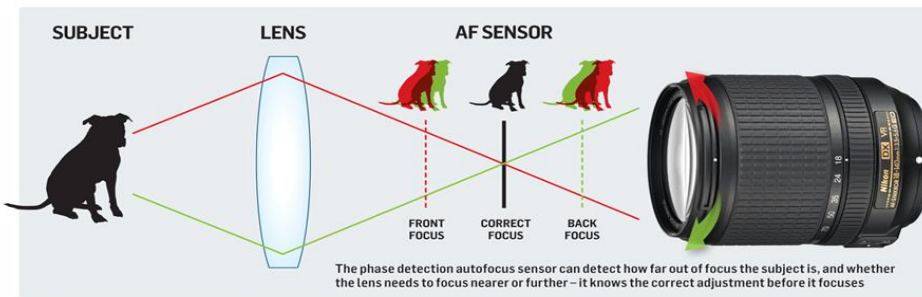

The phase detection autofocus sensor can detect how far out of focus the subject is, and whether the lens needs to focus nearer or further – it knows the correct adjustment before it focuses

First look at the lens diagram above...the dog on the right is fuzzy close and the dog on the left is fuzzy far, but the one in the middle is "just right".

Okay, so your camera looks at the scene and picks the dog on the right...it then asks itself how far out it is and which direction and instantly (or sooner in the case of Nikon) it shouts some numbers at its algorithm to slam that lens to the proper

spot for the sharpest picture in the known universe. But wait,,, what if it is a coupla numbers off or maybe the lens through wear or age coasts a little or stops a little short? Believe me when I say this has happened to other people before. Some cameras and lenses let you adjust for this (by fudging the numbers) so you always come out right at the black dog. Larry even has a hedge in his back yard he has half worn out adjusting his lenses for total perfection.

In contrast (pun intended) to this, contrast focus is what you do when you were too cheap to buy the autofocus lens and instead got the \$1.98 special on a manual focus at Lensorama. You look through the viewfinder, see the fuzzy image and turn the focusing ring until it gets sharp...then you go just past it to be sure and then turn it back to sharp again etc. for about three, four or more times until it makes you happy...then push the button to make your image.

Your camera can do this too but it is a little smarter than you...it knows which direction to go and even how far by the degree of out of focusness it sees. It can then run the focus to the black dog in under three tries. This is a much slower process that has been and is still used in some point and shoot cameras. The drawback is that it is a muuuuuch slower process.

This brings us to the third type of focusing (which I have, use and love), which is a combination of the two. Now the camera has even gotten smarter (for one thing, it has thrown out both mirrors from the DSLR) and now not only is smart enough to know how far and which direction to phase detect...but when it skids to a stop, it contrast focuses just enough to make sure...and it does all this in 0.002sec. I get up every morning and bow to my camera and say thank you for being so much smarter than me.

Okay, I didn't say anything about the first image above. It shows the focusing hardware used in most DSLR's and I will save an explanation for another time. It's time for my nap.

Thanks for listening and keep snapping...Dick

---

**Traditional Monochrome Print - 02/04/19**

<b>Maker</b>	<b>Title</b>	<b>AVERAGE</b>	<b>AWARD</b>	<b>Spread</b>
Thomas Konomos	Pistol Packing Mama	7.571	1st	3
Tony Mason	Strapped On	7.333	2nd	2
Tony Mason	Road To Above	7.333	2nd	3
Carol Pomes	Beloved	7.200	3rd	3
Darla Parthemore	Downtown San Francisco	7.077	HM	3
Dick Chambers	Concrete Curl	7.067	HM	2
Elise Ciralo	Bryan	7.067	HM	3
Darla Parthemore	The Overlook	7.000		4
Tony Mason	Earth To Sky	7.000		2
Carol Todd	Not The Hub	6.933		2
Elise Ciralo	Graffiti Paint-over	6.933		2
Thomas Konomos	Wee	6.933		2
Elise Ciralo	Rings	6.867		2
Thomas Konomos	Player	6.867		2
Carol Pomes	Lake McDonald Bridge	6.786		3
Carol Pomes	The Chase	6.533		4



The most important thing I have to say right now is **VOLUNTEER, VOLUNTEER and MORE VOLUNTEER**. Yes as you can tell we need volunteers for our club to be a success. At our last meeting, we outlined a list of volunteer opportunities we need for the upcoming year. If you are so inclined, please let a board member know you are interested. (Even if you aren't inclined but want to make OUR club a success!)

**A HUGE THANK YOU** to Blayden Tompson for volunteering to be our new webmaster. Our current website comes due on April 1<sup>st</sup> and it has gone way up in price so Blayden is reconfiguring a new site for us. Be on the lookout for that!

Our table top shootout at Elise C's on February 16<sup>th</sup> was a fun event. We had 8 participants join in on the fun.

Until we meet again, Renee

**1<sup>st</sup> Place Traditional Color EID  
Larry Mikulecky - Attention**



<b>Traditional Color Electronic - 01/21/19</b>				
<b>Maker</b>	<b>Title</b>	<b>AVERAGE</b>	<b>AWARD</b>	<b>Spread</b>
Larry Mikulecky	Attention	7.706	1st	2
Darla Parthemore	Half Dome	7.647	2nd	3
Tony Mason	I, AM ZACH	7.529	3rd	3
Tony Mason	There's Room For Two 2	7.529	3rd	3
Don Todd	Bee Having	7.412	HM	4
Larry Mikulecky	Break Time	7.412	HM	3
Carol Pomes	Christmas Honor	7.353	HM	3
Tony Mason	The View Doesn't Pay The Rent	7.235		8
Linda Petersen	Desert Sunset	7.118		3
Carol Pomes	Pacific View	7.000		2
Darla Parthemore	The Heel Stone	6.882		2
Don Todd	Slow Flow	6.882		4
Larry Mikulecky	European Widgeon	6.882		3
Linda Petersen	Snowy Tree At Odell Lake	6.882		4
Carol Todd	Dunes	6.824		3
Renee Marcov	Port & Rope	6.824		2
Carol Todd	Iron Gate	6.706		3
Don Todd	White Splendor	6.706		3
Renee Marcov	Elk On The Smith	6.706		2
Linda Petersen	Four And Twenty Redwing Blackbirds	6.647		2
Renee Marcov	Rouge River Fog	6.588		3
Cathy Stevenson	Bandon Facerock Sunset	6.529		2
Carol Pomes	Canadian Geese	6.471		2
Cathy Stevenson	Santiam Wagon Road Corral	6.471		1
Carol Todd	Hollering Pt. View	6.353		3
Darla Parthemore	The Rook	6.353		3

**Editors Notes:** March 10<sup>th</sup> we return to **Daylight Savings Time!** Don't forget to Spring forward!

Many positions will be opening up as Tony has decided to lighten his load. No, he isn't leaving the club, but he is looking to spend more time photographing and less time on club demands. A few of the jobs up for grabs are EID competition chair, 4C's EID chair, 4C's representative, projectionist, Scavenger Hunt presenter, Competition Statistic Keeper, End of year Challenge, Power Point Presenter etc. I expect we will be looking at opportunities for others to step up and take on a few of these jobs. Carol T

**1<sup>st</sup> Place Traditional Color Print  
Tom Branderhorst -Tasty Snack**



<b>Traditional Color Print - 01/21/19</b>				
<b>Maker</b>	<b>Title</b>	<b>AVERAGE</b>	<b>AWARD</b>	<b>Spread</b>
<b>Tom Branderhorst</b>	<b>Tasty Snack</b>	<b>7.588</b>	<b>1st</b>	<b>2</b>
<b>Tony Mason</b>	<b>Upper East Fork Coquille River Falls</b>	<b>7.471</b>	<b>2nd</b>	<b>3</b>
<b>Renee Marcov</b>	<b>Moth On Yellow Flower</b>	<b>7.353</b>	<b>3rd</b>	<b>2</b>
<b>Carol Pomes</b>	<b>Big Eyes</b>	<b>7.235</b>	<b>HM</b>	<b>3</b>
<b>Carol Pomes</b>	<b>Sunny</b>	<b>7.235</b>	<b>HM</b>	<b>3</b>
<b>Dick Chambers</b>	<b>Small Craft Warning</b>	<b>7.235</b>	<b>HM</b>	<b>3</b>
Renee Marcov	Pollen Gatherer	7.118		2
Tom Branderhorst	Flying Away	7.059		2
Elise Ciralo	Bodie Buildings	7.000		3
Tony Mason	Cathedral Valley	7.000		2
Tony Mason	Up Against It	6.941		2
Tom Branderhorst	Blue Heron Statue	6.882		2
Dick Chambers	Whitehorse Falls	6.765		2
Elise Ciralo	Curves	6.706		2
Elise Ciralo	Fading Light	6.706		2
Carol Pomes	In The Snow	6.588		3

**Traditional Monochrome Electronic - 02/04/19**

<b>Maker</b>	<b>Title</b>	<b>AVERAGE</b>	<b>AWARD</b>	<b>Spread</b>
<b>Tony Mason</b>	<b>Erosion Of Time</b>	<b>8.133</b>	<b>1st</b>	<b>2</b>
<b>Carol Pomes</b>	<b>Lake McDonald</b>	<b>7.533</b>	<b>2nd</b>	<b>3</b>
<b>Darla Parthemore</b>	<b>St. Augustine Abbey</b>	<b>7.533</b>	<b>2nd</b>	<b>1</b>
<b>Carol Pomes</b>	<b>Going To The Chapel</b>	<b>7.467</b>	<b>3rd</b>	<b>1</b>
<b>Tony Mason</b>	<b>Crooner Extraordinaire</b>	<b>7.467</b>	<b>3rd</b>	<b>2</b>
<b>Blayden Thompson</b>	<b>Foggy Overpass</b>	<b>7.333</b>	<b>HM</b>	<b>3</b>
<b>Elise Ciralo</b>	<b>Wave Action</b>	<b>7.267</b>	<b>HM</b>	<b>2</b>
Cathy Stevenson	Room With A View	7.133		2
Carol Pomes	John Day Ranch	7.067		3
Don Todd	Just Dandy	7.067		3
Don Todd	Welcome Home	7.000		2
Don Todd	Dah Bridge	6.933		2
Darla Parthemore	Old Man By The Sea	6.867		2
Darla Parthemore	Tree Reflections	6.867		2
Bonnie Graham	Pacific Belle	6.733		3
Bonnie Graham	Textured Shell	6.533		3
Cathy Stevenson	Rugged	6.533		2
Bonnie Graham	Got Gas	6.467		3
Elise Ciralo	Forest Flora	6.467		2
Elise Ciralo	Trunks	6.467		3
Tony Mason	The Look Of Hope	6.429		8
Cathy Stevenson	Snow On Glasgow	6.400		2



**1<sup>st</sup> Place Traditional Monochrome  
Tony Mason - Erosion of Time**



## 4Cs Monthly EID February Results

As OCPA judge in January, we were able to enter double the normal amount (10 instead of 5). 98 total images were entered from 19 clubs and they were judged by the Southern Oregon Photographic Society (Medford). You needed a score of 24-22 to receive an AM and a 22 to receive an HM.

Forest Grove is currently in the lead with a total of 551 club points. OCPA is in 15<sup>th</sup> Place with 392 points. There are three more (March, April & May) competitions left in this 2018-19 season.

<b>Winter Quarter EID</b>					
<b>Altered Reality</b>					
<b>Maker</b>	<b>Title</b>	<b>Judge 1</b>	<b>Judge 2</b>	<b>Judge 3</b>	<b>Total</b>
Carol Todd	Tim's Victory	5	7	5	17
Renee Marcov	Whacky Christmas House	6	6	6	18
<b>44 total images: 25-24 points for AM &amp; 24-23 for HM</b>					
<b>Monochrome</b>					
<b>Maker</b>	<b>Title</b>	<b>Judge 1</b>	<b>Judge 2</b>	<b>Judge 3</b>	<b>Total</b>
Darla Parthemore	Abandon Lighthouse	6	6	7	19
Carol Pomes	Out For A Walk	5	6	7	18
Renee Marcov	On The Pumpkin Farm	6	5	5	16
<b>58 total images: 25-24 points for AM &amp; 23 for HM</b>					
<b>Traditional (color)</b>					
<b>Maker</b>	<b>Title</b>	<b>Judge 1</b>	<b>Judge 2</b>	<b>Judge 3</b>	<b>Total</b>
Darla Parthemore	Sunset Bay	8	7	8	23
Bonnie Graham	Pink Water	6	6	8	20
Carol Pomes	Viewpoint Beauty	6	6	7	19
Carol Todd	Hollering Point	7	6	6	19
Bonnie Graham	Orange Fire	5	6	6	17
Carol Pomes	Red Madrone	7	5	5	17
Darla Parthemore	Cape Arago Sunset	6	6	5	17
Bonnie Graham	Funky Flower	5	6	6	17
Renee Marcov	Creamy Blue Water	6	6	5	17
<b>156 total images: 25-23 points for AM &amp; 23 for HM</b>					
<b>Judge by the Spokane Valley Camera Club</b>					

Check out the winning image gallery on the 4Cs website (currently not up-to-date):  
[http://columbiacameraclubs.org/content.aspx?page\\_id=187&club\\_id=772283](http://columbiacameraclubs.org/content.aspx?page_id=187&club_id=772283)

Traditional Color Electronic - 01/21/19				
Maker	Title	AVERAGE	AWARD	Spread
Larry Mikulecky	Attention	7.706	1st	2
Darla Parthemore	Half Dome	7.647	2nd	3
Tony Mason	I, AM ZACH	7.529	3rd	3
Tony Mason	There's Room For Two 2	7.529	3rd	3
Don Todd	Bee Having	7.412	HM	4
Larry Mikulecky	Break Time	7.412	HM	3
Carol Pomes	Christmas Honor	7.353	HM	3
Tony Mason	The View Doesn't Pay The Rent	7.235		8
Linda Petersen	Desert Sunset	7.118		3
Carol Pomes	Pacific View	7.000		2
Darla Parthemore	The Heel Stone	6.882		2
Don Todd	Slow Flow	6.882		4
Larry Mikulecky	European Widgeon	6.882		3
Linda Petersen	Snowy Tree At Odell Lake	6.882		4
Carol Todd	Dunes	6.824		3
Renee Marcov	Port & Rope	6.824		2
Carol Todd	Iron Gate	6.706		3
Don Todd	White Splendor	6.706		3
Renee Marcov	Elk On The Smith	6.706		2
Linda Petersen	Four And Twenty Redwing Blackbirds	6.647		2
Renee Marcov	Rouge River Fog	6.588		3
Cathy Stevenson	Bandon Face Rock Sunset	6.529		2
Carol Pomes	Canadian Geese	6.471		2
Cathy Stevenson	Santiam Wagon Road Corral	6.471		1
Carol Todd	Hollering Pt. View	6.353		3
Darla Parthemore	The Rook	6.353		3



## OCPA Board Meeting Minutes February 2019

February 11, 2019, 6:36 PM, President Renee Marcov called the meeting to order at Dick and Kathy Chambers' home. Board members present were Tony Mason, Don Todd, Curt Benward, Bonnie Smith, Renee Marcov, Dick Chambers, Peggy Cooper and Kathy Chambers. Guests present were: Blayden Thompson, Bonnie Graham and Carol Todd.

Curt moved, and Dick seconded that we accept the minutes from the January board meeting as written. Motion carried.

Don gave the treasurer's report.

		Previous balance	\$3,058.99
Income:	Dues	\$15.00	
		Total Income	\$15.00
Expenses:	4Cs Travel	\$50.00	
	Petty Cash	\$15.00	
		Total Expense	\$65.00
		Ending Balance	\$3008.99

Kathy moved, and Bonnie S. seconded that we accept the treasurer's report. Motion carried.

### Committee Reports:

Pony Village Mall Show/Sale The Spring Pony Village Show/Sale will be held April 25th-28<sup>th</sup>. Take in will be on Wednesday the 24<sup>th</sup> at 5:30. We will be situated in front of JoAnn's Fabrics. Fair Take in will be July 20<sup>th</sup> and 21<sup>st</sup>. Judging will be July 22<sup>nd</sup>. Fair will run July 23<sup>rd</sup>-27<sup>th</sup>. Take down will be July 28<sup>th</sup>.

Fund Raising The garage sale will probably be in the late Spring or early Summer.

Shoot-out A macro/table-top shoot-out will be February 16<sup>th</sup>, 5:00PM at Elise Ciraolo's home.

Website Blayden is looking into the website. He said there are four things to consider and we arranged them in importance: 1. Access to information, 2. Support for members, 3. New member interest and 4. Cost. Blayden will look into and compare some websites and we will have a special board meeting after the next regular meeting. He feels like we have enough time to deal with a new website before the old one expires at the end of April.

4C's Prints Renee needs large prints for the next competition.

EID Our requirement for image size is different than 4C's. We will discuss this more before the annual meeting.

4C's The next convention is in April at Hood River.

Member's Only We have been getting some great images, thank you membership.

Newsletter The deadline for getting information in the newsletter is February 23<sup>rd</sup>. Members need to contribute more to the newsletter.

**Old Business** We will be doing some shootouts this Spring with the Mavica's and with some Casio's of Tony's.

Since Tony is leaving, we need to get a list together of all the jobs that need to be filled. Tony, Carol T. and Renee will discuss the list after their class on Wednesday. Carol P. is interested in taking over as 4C's rep.

There being no further business the meeting was adjourned at 8:06.

Respectfully Submitted,

Kathy Chambers

OCPA Secretary

## OCPA Special Board Meeting Minutes

February 18, 2019, 6:36 PM, President Renee Marcov called the meeting to order with Bonnie Smith, Renee Marcov, Tony Mason, Carol Pomes, Kathy Chambers, Dick Chambers, Curt Benward and Blayden Thompson present.

Blayden has checked out some websites and he thinks that Weebly might work for us. He is checking out the free version versus the pay version. The pay version is \$144.00 a year. The formatting is going to look a little different than the old website. It includes 3 or 5 emails and will accept links to other sites. He will try to get something ready for us to see.

There being no further business the meeting was adjourned at 8:34.

Respectfully Submitted,

Kathy Chambers

OCPA Secretary



## Around Town

### Art by the Sea - Call to Artists

PHOTOGRAPHY SHOW - "Eye and the Lens"

March 5 to March 31, 2019

For information on entering this show go to [www.artbytheseagallery.com/call-to-artists](http://www.artbytheseagallery.com/call-to-artists) .  
Entries are due by March 4, so don't delay!

### Photography Exhibit

Photography exhibit by Gloria Cole at the South Slough Reserve. It is collection of photography of some of her favorite places mostly in the Pacific Northwest. The opening reception is Saturday, March 2 from 1:00 – 3:00 PM. The show will remain on display through the month of April.

### Lecture

The SWOCC Geology Club will be sponsoring a lecture on "The Oregon Dunes: Past, Present and Future". The presenter, Dina Pavlis, is a volunteer interpretive ranger, author and photographer. The presentation will be on Monday, February 25 at 2:00 PM in Eden Hall. If you miss the lecture, they are posted to the SWOCC Geology Department web sites <https://www.socc.edu/geology> and YouTube.

### Books

The Beginner's Guide Photography Guide by Chris Gatum

The Advance Photography Guide by David Taylor

Both these books are DK books by Penguin Random House publishers at the Coos Bay Public Library. The beginner's guide has been on the shelves for a while and the advanced guide is new. To be honest both books are pretty basic and club members probably know most of the material in the books. Still it you might be surprised by some new information and it is amazing how much stuff you know about but kind of forgot.

## **Links**

### **Southcoast Striders**

<http://coostrails.com/coostrails/index.html>

The home page for the Southcoast Striders. You can get on their mailing list for emails on upcoming hikes. The next ones in March are Hecta Head March 9 and Gold and Silver Falls March 23. There is a link on the home page to photos from the Hall Lake hike and you will see Darla!

### **Treasure Valley Photo Club**

<http://www.treasurevalleycameraclub.com/>

This is the link for the new 4C's club, Treasure Valley. Don T. mentioned it at our board meeting and I saw it when looking for web site designs. It is a nice web site. Under the Reference Material tab go to Meeting Presentations and you will find one they did on Astrophotography. Good introduction for the club's field trip this summer.

### **Circles in the Sand**

The following are the dates that are scheduled for 2019 labyrinth drawings on Bandon Beach.

Contact: [www.sandypathbandon.com/public-schedule](http://www.sandypathbandon.com/public-schedule)

March 16 (evening), 17 (evening), 23 & 24 (days)

April 20, 21, 22 (days)

May 5, 6, 7, 8, 9, 19, 20, 21, 22

June 2, 3, 4, 5, 6, 7, 8, 9, 16, 17, 18, 19, 20 (days)

July 4, 5, 6, 7, 18, 19, 20, 21 (days)

August 2, 3, 4, 5, 16, 17, 18 (days)

September 1, 2 (days)

*Thank you Curt and Don for compiling this information*

### **Pony Village**

Hey Folks! It's almost time for the Pony Village Show & Sale at the Pony Village Mall! Image hanging will be on April 24th, 2019 starting at 5:00 PM; and the Show & Sale will be April 25th through April 28th during regular mall hours. All OCPA members are encouraged to participate with images of every type. Additionally, we have added photography related items to our Show & Sale. This can include picture frames, jewelry items, printed Tee Shirts and other items ,, as long as they are created/decorated by our members.

And remember, all participants need to sign up to "baby-sit" during the event, but if unable to sit, please ask another member to fill in for you, or call me. The sign-up sheet will be available at our regular OCPA meetings through Monday, April 22, 2019, as well as scheduled board meetings. We are looking forward to another fun and profitable show and sale. See you there!  
Bonnie Smith

## CALENDAR OF EVENTS MARCH 2019

### **Mar 4 - Meeting - North Bend Senior Center**

#### **Take in and Social 6:30 PM - Activities Starts 6:45 PM**

Ha Ha (Humor), Show & Tell, Critique, After & Before, 4Ws (Who, What, When, Where), & What's New to You? Competition: Traditional Color (5 of 5)

Photo Theme Challenge: "Green"

### **Mar 11 - Board Meeting, 6:30 PM,**

Chamber's Home (all members are invited to come)

### **Mar 18 - Meeting - North Bend Senior Center**

#### **Take in and Social 6:30 PM - Activities Starts 6:45 PM**

Ha Ha (Humor), Show & Tell, Critique, After & Before, 4Ws (Who, What, When, Where), & What's New to You? Competition: Traditional Monochrome (5 of 5)

Photo Theme Challenge: "Road or Path"

## CALENDAR OF EVENTS APRIL 2019

### **Apr 1 - Meeting - North Bend Senior Center**

#### **Take in and Social 6:30 PM - Activities Starts 6:45 PM**

Ha Ha (Humor), Show & Tell, Critique, After & Before, 4Ws (Who, What, When, Where), & What's New to You? Competition: Photo Theme Challenge: Showers, Member's Only

Competition: Creative/Graphic (5 of 5)

### **Apr 08 - Board Meeting, 6:30 PM,**

Chamber's Home (all members are invited to come)

### **Apr 13 - Shoot Out**

### **Apr 15 - Meeting – North Bend Senior Center**

#### **Take in and Social 6:30 PM - Activities Starts 6:45 PM**

Ha Ha (Humor), Show & Tell, Critique, After & Before, 4Ws (Who, What, When, Where), & What's New to You? Competition: Photo Theme Challenge: Still Life. Scavenger Hunt

Begins

### **Apr 24 – 5 PM - Pony Village Set Up**

### **Apr 25 – 28 – Pony Village Mall Show**

### **Apr 28 – Pony Village Take Down**

## Current OCPA Board and Contact Information

Position	Name	Email Address
1	Tony Mason,	tony20@ oregoncoastphotoclub.com
2	Curt Benward	cbenward@ frontier.com
3	Carol Pomes, Vice President	cpomes@earthlink.net
4	Renee Marcov, President	coastalgma@ gmail.com
5	Dick Chambers	picmon387@ gmail.com
6	Bonnie Smith	seekr50@ aol.com
7	Kathy Chambers, Secretary	katsmijo738@ gmail.com
8	Don Todd, Treasurer	Golden_Shellback@ yahoo.com
9	Peggy Cooper	Cooper.peg@gmail.com

**The PROOF SHEET** is published monthly by the OREGON COAST PHOTOGRAPHERS' ASSOCIATION, INC. and is completely supported by membership dues. All articles, features and other material printed do not necessarily reflect the views of OCPA's Board of Directors, officers, membership, associated organizations or editor(s) of this publication. Any and all brands, products or business names listed are copyrighted, trademarked and / or registered and are not necessarily endorsed by OCPA (other than our corporate sponsors).

Reprinting of articles from the PROOF SHEET, for use in non-commercial photography club newsletters, is permitted if the photo or article is not copyrighted, and credit is given to the author and this newsletter as the source of the information. Any other type of reproduction may be done with specifically written permission only. Inquiries about this publication may be made by directing them to the editor, c/o OREGON COAST PHOTOGRAPHERS' ASSOCIATION, INC., P.O. Box 5646, Charleston, OR 97420 or ocpaproofsheets @ yahoo. com

**Meetings:** 1st & 3rd Mondays of the month at North Bend Senior Center, 1470 Airport Lane (across the street from the Department of Human Services), North Bend, OR.

**How to Join the OCPA** Joining OCPA is very easy! Just come to one of our meetings and check us out. If you like what you see we'll take your membership dues and that is it!

If you want to join, but can't make a meeting, just write a check and mail it to us:

Oregon Coast Photographers' Association, Inc.

PO Box 5646

Charleston, OR 97420

**Membership Dues** are \$24.00 for individuals or \$36.00 for families (up to 2 adults and any/all children 17 years and under at the same address, everyone will have all membership privileges except only 2 votes per family). Dues are prorated for new members for the remaining months from when they join until the next July first annual meeting.

All **information** on club activities including, but not limited to, our by-laws, policies, and competition rules, can be found on our Website at [www.oregoncoastphotoclub.org](http://www.oregoncoastphotoclub.org). Schedule changes are available on our Website and Facebook page.